

Uniclass L4181	EPIC D181
CI/SfB (31.59) X	

MARCH 2003

# Coburn Straightaway 100SS®

## Stainless Steel Sliding Door Hardware

**Introducing the new Coburn Straightaway 100SS, the latest in hardware for interior and exterior straight sliding doors weighing up to 100Kg.**

Produced in 316 grade stainless steel and developed to cope with harsh operating environments, the Coburn Straightaway 100SS is ideal for applications within the food and chemical industries and can withstand extreme climatic conditions.

### DOOR CONSTRUCTION

- Suitable for doors of normal timber-framed construction, panelled, glazed or framed
- Adequate top rail required to provide secure fixing of hangar
- Maximum door thickness 50mm
- Maximum door height 2.5m
- Minimum door thickness 30mm when using floor guide channel
- Metal doors of light angle or channel construction, subject to minimum thickness of 40mm

### TOP TRACK

- 1-14(1.2mm) 316 grade stainless steel
- Drilled for brackets or soffit fixing
- Available as 1-14-21 (2.1m) and 1-14-30 (3.0m) lengths

### TRACK BRACKETS

- Stainless steel, side fixing with two screws
- Available with fixing screws as:
  - 1-405 (pack of 5 for 2.1m track length)
  - 1-408 (pack of 8 for 3.0m track length)

### HANGERS

- 1-403 for timber or metal doors
- Stainless steel construction, 4 nylon wheels, ball bearings lubricated for life
- Vertical and lateral adjustments



### DOOR GUIDES

- 44-371 Polypropylene Door Guide for interior timber doors up to 1500mm wide
- 44-415 Stainless steel Roller Guide suitable for metal doors of any width
- 44-446 Stainless steel Guide suitable for interior timber doors over 1500mm wide

*Note: All for use with 44-4 stainless Channel*

### TRACK END PIECE

1-419 Track End Piece with holdback catch.

Independent door stops (97-420) should be fitted at mid-height of door (see illustration).

### BOTTOM CHANNEL

44-4 stainless steel available as 44-4-21 (2.1m) and 44-4-30 (3.0m) lengths

### FINISHES

Track and components in natural stainless steel finish

### PERFORMANCE

All Straightaway 100SS sliding door gear fittings have been tested for endurance and strength. Each type of 4 wheel hanger, together with its associated fittings has been loaded to the maximum stated capacities and tested over 100,000 cycles without failure.

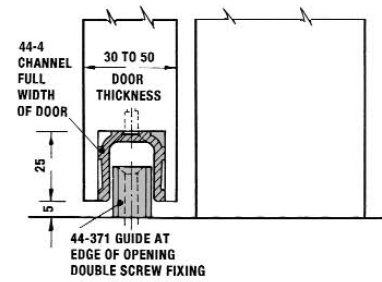
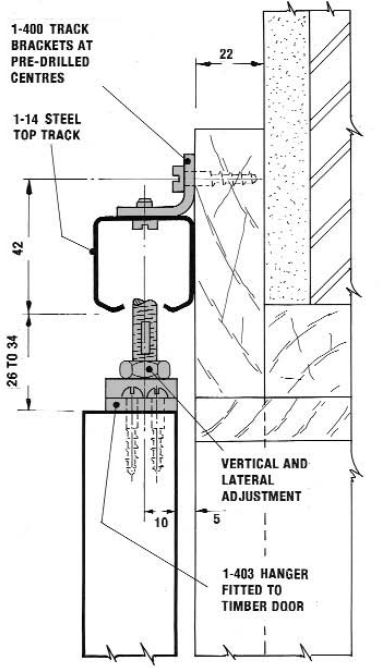

GUIDING FOR INTERIOR TIMBER DOOR UP TO 1500mm WIDE

SECTION THROUGH OPENING

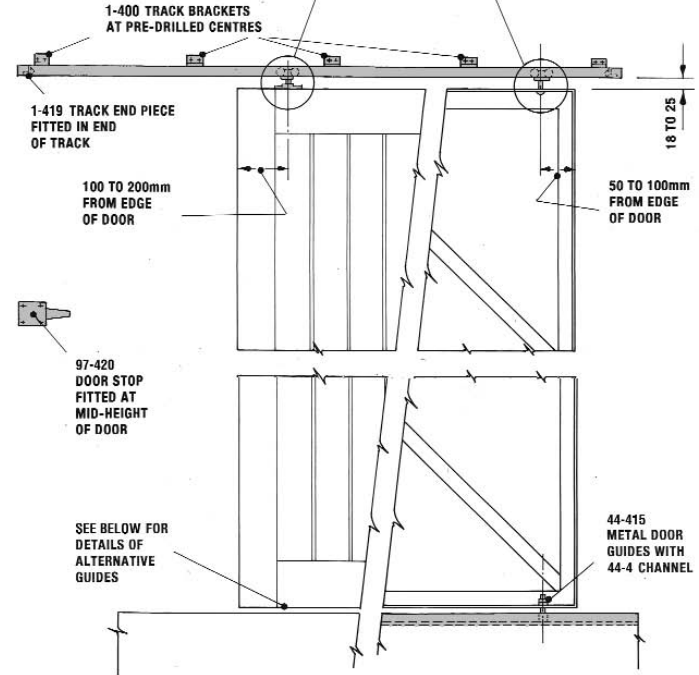
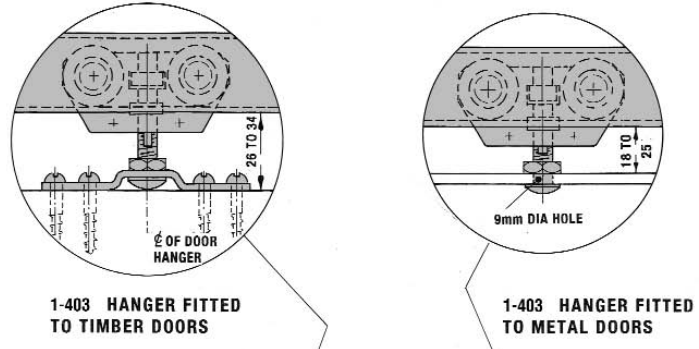

ELEVATION OF TIMBER AND METAL DOORS



PLAN OF DOORS

ALTERNATIVE BOTTOM GUIDING:

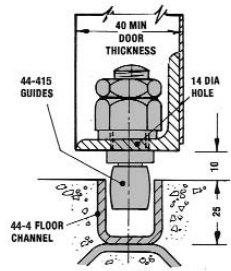

METAL DOORS ANY WIDTH

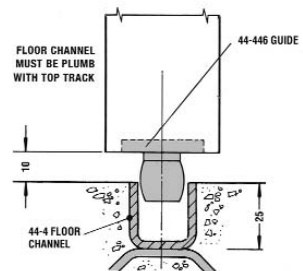

TIMBER DOORS OVER 1500MM WIDE

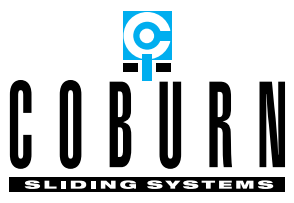

HILLALDAM COBURN LIMITED

**HEAD OFFICE**  
Unit 6, Wyvern Estate,  
Beverley Way, New Malden,  
Surrey, KT3 4PH, England.

**Telephone:** 020 8336 1515  
**International:** +44 20 8336 1515  
**Facsimile:** 020 8336 1414  
**Sales Freefax:** 0800 616623  
**e-mail:** sales@hillaldam.co.uk  
**Web:** www.coburn.co.uk

**SCOTLAND**  
Unit 25 Baillieston Distribution  
Centre, Glasgow, G69 6UL, Scotland.

**Telephone:** 0141 771 6165  
**Facsimile:** 0141 773 1693  
**Sales Freefax:** 0800 318904



Certificate No. FS 14679  
The products designed and  
supplied by Hillaldam Coburn  
Ltd are covered by a Quality  
Assurance system in accordance  
with BS EN ISO 9001:2000

The company reserves the right from time to time to make such alterations in design and manufacture as they consider necessary without notice. Drawings, specifications, illustrations, tables and other details are not binding in detail. Conditions of sale are as those published on the Company's tender forms.